

## ALUTRUSS TRILOCK S-PAC-52 5-Way Piece $\Lambda$

3-point truss system

Art. No.: 60302545

GTIN: 4026397559460

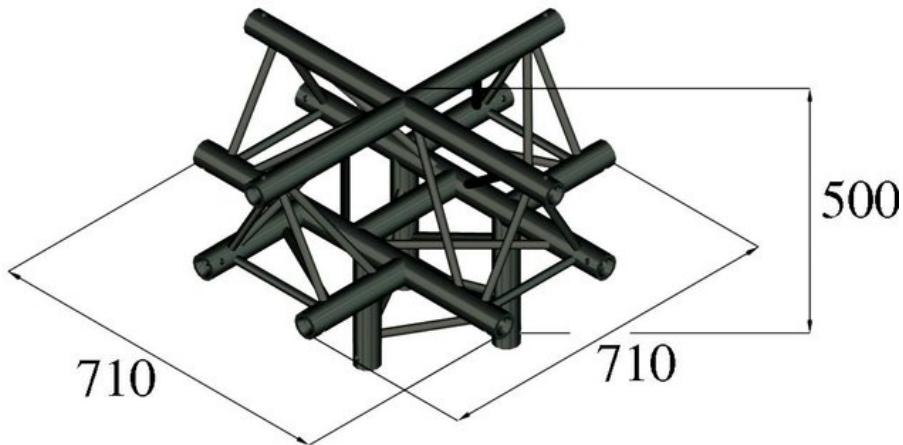

**The article is no longer in our assortment.**

### Features:

- Low weight
- Easy installation
- Trusspipe: 50 mm
- Made in Europe
- For application areas such as: Theater; Trade fair and shop fitting; Clubs/dancing school

### Logistic

EAN / GTIN: 4026397559460

Weight: 10,25 kg

Length: 0.71 m

Width: 0.71 m

Height: 0.50 m

### Technical specifications:

Setup: Easy installation

Trusspipe: 50 mm x 2 mm

Color: Black

Strut diameter x thickness: 16 x 2mm

Dimensions: Length: 71 cm  
Width: 71 cm  
Height: 50 cm

Weight: 9,95 kg